

INSTALLATION: DRIVER ENCLOSURE

Ceiling Type	Structure Mount
Version	Remote with Battery Pack

IMPORTANT SAFEGUARDS

When using electrical equipment, basic safety precautions should always be followed including the following:

READ AND FOLLOW ALL SAFETY INSTRUCTIONS.

- Installation and servicing should be performed by qualified service personnel.
- Install in accordance with the National Electrical Code, Canadian Electrical Code, and any local regulations.
- A Constant/Unswitched AC source is required (120 through 277 VAC, 50 or 60 Hz).
- The Constant/Unswitched lead must be fed from the same branch circuit as the Switched lead.
- The maximum mounting height of the suspended luminaire is 10 feet, for emergency lighting purposes.
- The luminaire is not suitable for wet or hazardous locations.
- To reduce risk of electric shock, disconnect both the Switched (normal) and Constant/Unswitched (emergency charging) connections before servicing the luminaire.
- Disconnect the battery pack “blade” fuse before servicing the batteries – line voltage compartment.
- Do not install near gas or electric heaters.
- Equipment should be installed in locations and at heights where it will not be subjected to tampering by unauthorized personnel.
- The use of accessory equipment not recommended by the manufacturer may cause an unsafe condition.
- Do not use this equipment for other than its intended use.

SAVE THESE INSTRUCTIONS



TOOLS + MATERIALS REQUIRED

Tools:

- Ceiling Anchor Tools
- Laser Line Tool
- Measuring Tool
- Lineman Pliers
- Conduit & Wiring Tools
- Phillips Screwdriver

Materials:

- Ceiling Anchors
- 4 inch Octagon J-Box
- Screws (for wall mount)

INSTALLATION

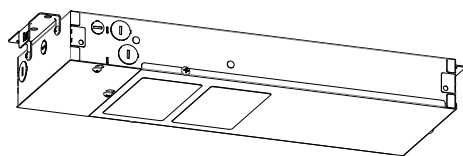
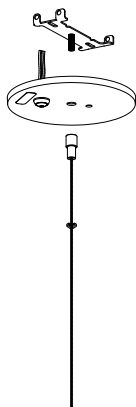

IMPORTANT

All fixtures should be installed in accordance with national and local building and electrical codes.

This product can be installed in recessed ceilings if proper access and spacing criteria is met.

In recessed or non-recessed installations, keep insulation, building members, and other driver enclosures at least 3 inches (76mm) away from all sides of the enclosure.

In addition, for model IDC-R24 or models IDC-R2101 through to IDC-R2600, note the following regulatory requirement. Install with minimum spacing between:

- center-to-center of adjacent luminaires: 24 inches (600mm)
- top of luminaire driver enclosure to overhead building member: 0.5 inches (13 mm)
- luminaire driver enclosure mount center to side of building member: 12 inches (300mm)

1 DETERMINE SUSPENSION POINT LOCATIONS

Refer to Row Configuration Document

Layout the luminaire suspension point locations and create a center line along the luminaire run using a laser or chalk line. Luminaire suspension points are 48" or 96" apart, depending on the luminaire. For a continuous run luminaire, note the location of the "non-power" suspension point (one point in from one of the ends).

3 MOUNT DRIVER ENCLOSURE

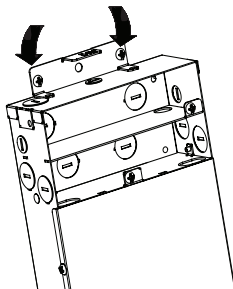

Mount driver enclosure to the ceiling or wall using 1/4-20 anchors or appropriate screws (supplied by others).

- NOTE:
1. Observe spacing requirements.
 2. See table of distance vs. wire gauge on last page.

5 RECESSED J-BOX OPTION: SUSPENSION BRACKET + WIRING

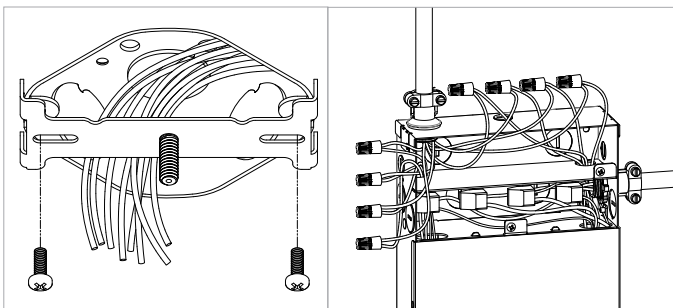

1. Mount the brackets to the J-Box using J-Box screws (by others)
2. For PRE-INSTALLED RECESSED Octagon Junction Boxes and Conduit:
Wire the J-box with 8 low voltage wires from the Remote Driver Enclosure (see table of distance vs. wire gauge for fixture current carrying wires).

2 RECESSED J-BOX OPTION: LINE VOLTAGE WIRING

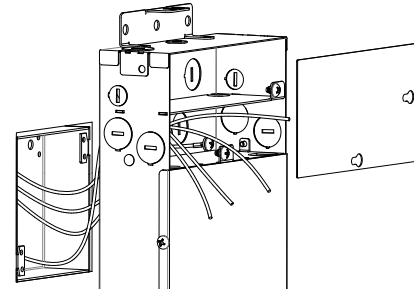

For RECESSED Junction Box only:

1. Break the rear knockout and feed source line voltage wires in driver box "line voltage cavity".
2. Connect wires to driver after mounting driver enclosure.

- NOTE: For Dimming Control Wiring:
1. Follow product label indicating whether dimming wiring is Class1 or Class2, Class1 Only, or Class2 Only.
 2. Wire recessed J-box dimming control wires as Class1 with the line voltage wires or in separate conduit.

4 SURFACE J-BOX OPTION: LINE VOLTAGE WIRING

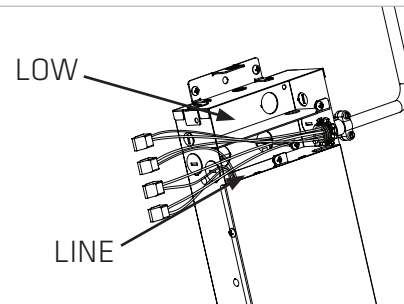

For SURFACE Junction Box + Conduit only:

Wire the source line voltage to driver box "line voltage cavity" from either side and connect wires to driver wiring.

- NOTE:
- The driver enclosure can be used as a junction box to daisy chain source line voltage wiring to the next luminaire.

- For Dimming Control Wiring:
1. Follow product label indicating whether dimming wiring is Class1 or Class2, Class1 Only, or Class2 Only.
 2. For Class1 dimming control wiring, make connections in Line Voltage Cavity and wire field dimming wires with the line voltage wires or in separate conduit.
 3. For Class2 dimming control wiring, route the driver dimming wires through the barrier hole to the Low Voltage Cavity and make connection to field Class2 dimming wires in the Low Voltage Cavity. Use the knock-outs in the Low Voltage Cavity for the field Class2 dimming wires. A duplex conduit fitting (by others) will be required for the 1/2" trade knockout to accommodate both the fixture low voltage wiring and Class2 dimming control wiring.

- NOTE:
1. The battery test switch requires 4 wires, all can be 18 AWG for any distance. Preferred colors: black, black, red, blue.
 2. An 8 foot fixture has 4 current carrying wires. A 4 foot fixture has 2 current carrying wires.

Skip to step #8 for non-power suspension points.

6 SURFACE J-BOX OPTION: INSTALL J-BOX + SUSPENSION BRACKETS

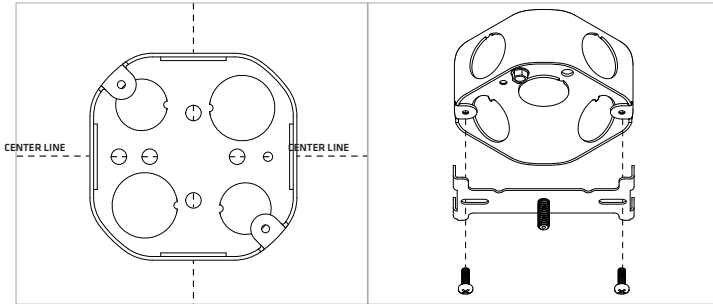

1. Using the ceiling center line, align octagon J-Box (by others) and mount it per national standards for suspended products.
2. Mount the bracket to the J-box using J-Box screws (by others).

NOTE: This applies for power and non-power suspension points.

8 WIRE BATTERY PACK SWITCH WIRES + INSTALL CEILING CANOPY + AIRCRAFT CABLE

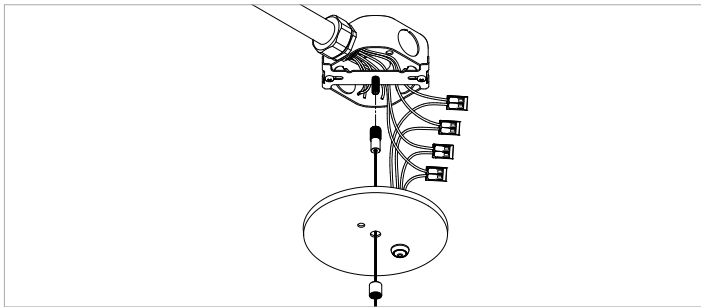

1. Install aircraft cable and remove outer threaded sleeve.
2. Connect appropriate battery switch wires to the 4 battery switch wires in the J-box using supplied lever nuts.
3. Temporarily install ceiling canopy with threaded sleeve.

7 SURFACE J-BOX OPTION: WIRING SUSPENSION POINT

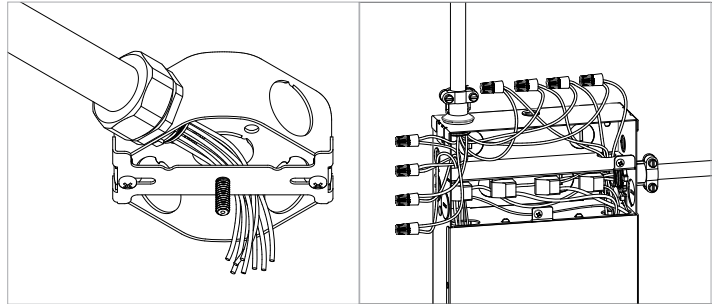

Wire the J-box with 8 low voltage wires from the Remote Driver Enclosure (see table of distance vs. wire gauge for fixture current carrying wires).

NOTE:

1. The battery test switch requires 4 wires, all can be 18 AWG for any distance. Preferred colors: black, black, red, blue.
2. An 8 foot fixture has 4 current carrying wires. A 4 foot fixture has 2 current carrying wires.

9 INSERT FUSE AFTER CIRCUIT IS ENERGIZED

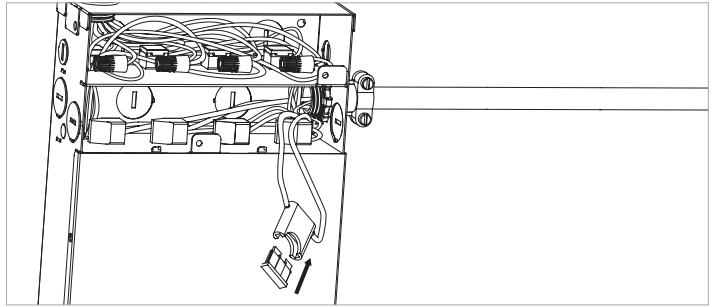

Insert fuse after fixture drop cord wires are connected and after branch circuit is energized.

Distance (ft), up to:	Recommended Wire Gauge for Minimal Losses (AWG)
30	18
50	14
80	12

Table 1. Low Voltage Distance vs. Wire Gauge

OPERATION

When the circuit is energized, the charging indicator light is illuminated, indicating the batteries are being charged. When power fails, the internal emergency driver automatically switches to emergency battery power, operating the luminaire at over 1500 lumens output. When the circuit power is restored, the emergency driver returns to charging mode. The emergency driver will operate the luminaire at over 1500 lumens output for a minimum of 90 minutes.

MAINTENANCE

Although no routine maintenance is required to keep the emergency luminaire functional, it should be checked periodically to ensure that it is working. The following schedule is recommended:

1. Visually inspect the charging indicator light monthly. It should be illuminated.
2. Test the emergency operation of the luminaire at 30-day intervals for a minimum of 30 seconds by depressing the test switch. The luminaire should switch to battery operation and illuminate.
3. Conduct a 90-minute discharge test once a year by de-energizing the lighting circuit. The emergency luminaire should be illuminated for a minimum of 90 minutes.

TROUBLE SHOOTING + REPLACEMENT

*** Servicing should be performed by qualified service personnel ***

If the luminaire fails to light during an emergency test, the output fuse or the batteries may need replacing. De-energize both the Constant/Unswitched and Switched circuits.

- Open the driver enclosure line voltage wiring compartment and locate the yellow fuse holder and remove the fuse. Replace the fuse if necessary with a new 2 A, 32 Vdc non-time delay blade fuse.
- Contact Fluxwerx for replacement batteries, NOT Philips Bodine. To replace the batteries, first remove the fuse from the yellow fuse holder, then disconnect the battery cable connections (pull apart) in the driver compartment and unscrew the sheet metal bracket. Re-assemble in reverse order. The batteries are Nickel-Cadmium rechargeable batteries and must be recycled or disposed of properly, per local regulations.



IMPORTANT

THIS PRODUCT CONTAINS NICKEL-CADMIUM BATTERIES. BATTERIES MUST BE RECYCLED OR DISPOSED OF PROPERLY